

SE Current Monitoring Series H608-S6



SPECIFICATIONS

Sensor Power	Induced from monitored conductor
Amperage Range	0.5 to 175 A Continuous
Status Output Ratings	N.O. 1.0 A@30 VAC/DC, not polarity sensitive
Insulation Class	300 VAC RMS, insulated conductors only
Setpoint	Adjustable
Frequency	50/60 Hz
Temperature Range	-15° to 60°C (5° to 140°F)
Humidity Range	10-90% RH non-condensing
Hysteresis	10% of setpoint (typical)
Off State Resistance	Open switch represents 1+ MΩ
On State Resistance	Closed switch represents <200 mΩ
Terminal Block Wire Size	0.2 to 2.1 mm ² (24 to 14 AWG)
Terminal Block Torque	0.4 to 0.5 N·m (3.5 to 4.4 in·lb)
Agency Approvals	CE:EN61010-1:2001
Installation Category	Cat. III, pollution degree 2

The Schneider Electric H608-S6 is a current-sensitive switching device that monitors current (amperage) in the conductor passing through it. A change in the conductor's amperage that crosses the adjustable switch threshold plus the hysteresis value causes the resistance of the FET status output to change state, similar to the action of a mechanical switch. The status output is adjustable using a 20-turn potentiometer (see the Calibration section). The status output is suitable for connection to building controllers or other appropriate data acquisition equipment operating at up to 30 volts. The H608-S6 requires no external power supply to generate its output.

For CE compliance, conductor shall be insulated according to IEC 61010-1:2010. The product design provides for basic insulation only. Do not use LED indicators as evidence of applied voltage.

DIMENSIONS

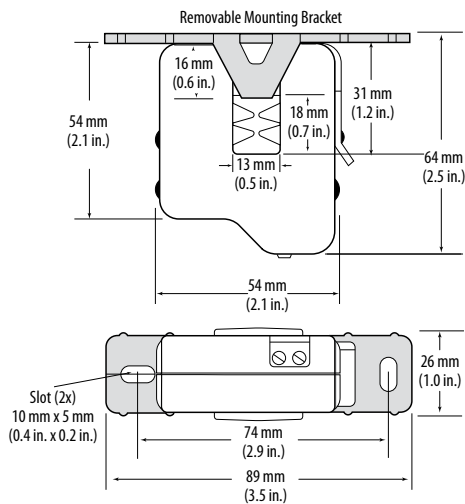

DANGER

HAZARD OF ELECTRIC SHOCK, EXPLOSION, OR ARC FLASH

- Follow safe electrical work practices. See NFPA 70E in the USA, or applicable local codes.
- This equipment must only be installed and serviced by qualified electrical personnel.
- Read, understand and follow the instructions before installing this product.
- Turn off all power supplying equipment before working on or inside the equipment.
- Use a properly rated voltage sensing device to confirm power is off.

DO NOT DEPEND ON THIS PRODUCT FOR VOLTAGE INDICATION

- Only install this product on insulated conductors.

Failure to follow these instructions will result in death or serious injury.

A qualified person is one who has skills and knowledge related to the construction and operation of this electrical equipment and the installation, and has received safety training to recognize and avoid the hazards involved. NEC2011 Article 100
No responsibility is assumed by the manufacturer for any consequences arising out of the use of this material.

NOTICE

- This product is not intended for life or safety applications.
- Do not install this product in hazardous or classified locations.
- The installer is responsible for conformance to all applicable codes.
- Mount this product inside a suitable fire and electrical enclosure.

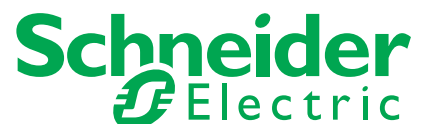

INSTALLATION

Disconnect and lock out power to the enclosure containing the conductor to be monitored.

1. Locate a mounting surface for the removable mounting bracket that will allow the monitored conductor to pass through the center window when it is installed and that will keep the product at least 13 mm (½ in.) from any uninsulated conductors. Determine cable routing for the controller connection, allowing wiring to reach the mounting location.
2. Drill holes to mount the bracket to the chosen surface using the included screws.
3. Wire the output connections between the sensor and the controller (solid-state contact).
4. Snap the sensor over the wire to be monitored and push the latch until it is securely closed. Clip the assembly to the mounting bracket.
5. Secure the enclosure and reconnect power.
6. Calibrate the current switch (see Calibration section).

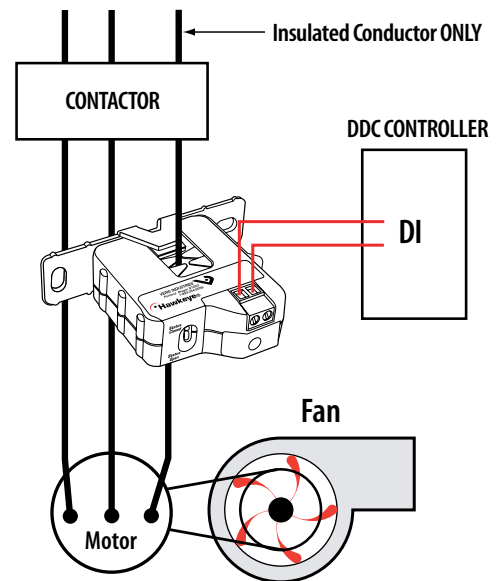

CALIBRATION

Before beginning calibration, establish normal load conditions.

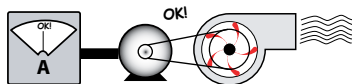

Then choose either A or B below.

A. To monitor under-current (belt loss, coupling shear, status)

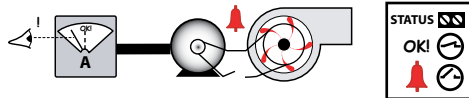

1. Turn setpoint screw clockwise until Status Open LED turns on.

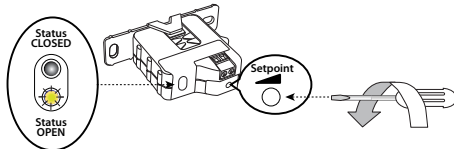

2. Slowly turn the screw counter-clockwise until the Status Closed LED just turns on.

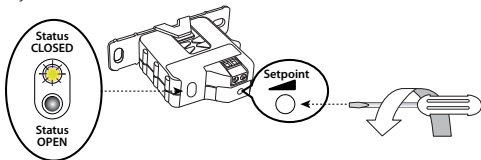

3. Turn the screw an additional 1/4 turn counter-clockwise for operational margin.

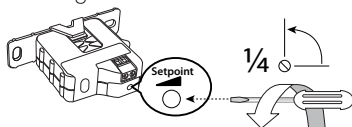

B. To monitor over-current (mechanical problems, seized impeller)

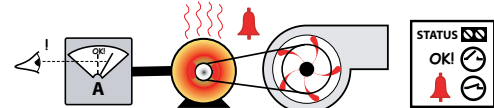

1. Turn setpoint screw counter-clockwise until Status Closed LED turns on.

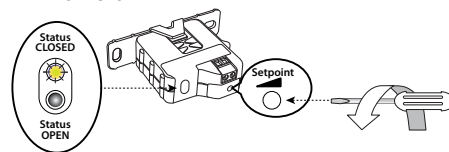

2. Slowly turn the setpoint screw clockwise until the Status Open LED just turns on.

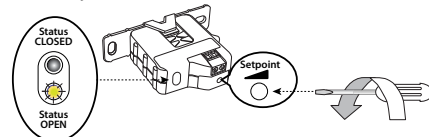

3. Turn the setpoint screw an additional 1/4 turn clockwise for operational margin.

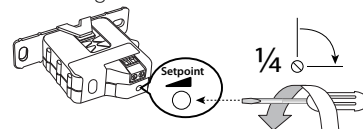

LOW CURRENT APPLICATIONS

For load currents less than sensor minimum rating, wrap the monitored conductor through the center window and around the sensor body to produce multiple turns. This increases the current measured by the transducer.

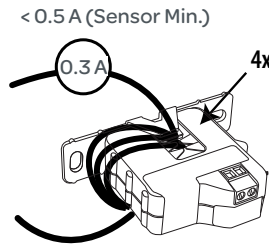

HIGH CURRENT APPLICATIONS

For load currents greater than sensor maximum rating, use a 5 Amp current transformer (CT) as shown. This technique can be combined with wrapping (see above) to add range for a low current load on a high current source.

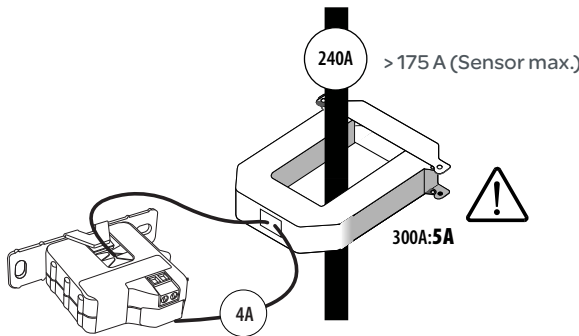

DANGER: 5A CTs can present hazardous voltages. Install CTs in accordance with manufacturer's instructions. Terminate the CT secondary before applying current.

CAUTION

RISK OF EQUIPMENT DAMAGE

- Derate the product's maximum current for the number of turns through the sensing window using the following formula.
Rated Max. Amps ÷ Number of Turns = Max. monitored Amps
 e.g. : $100\text{A} \div 4 \text{ Turns} = 25 \text{ Amps max. in monitored conductor}$
- Failure to follow these instructions can result in overheating and permanent equipment damage.

TROUBLESHOOTING

PROBLEM	SOLUTION
No Reading at Controller	<ul style="list-style-type: none"> • Check for control voltage at sensor ($<30\text{ V}$, $<1\text{ A}$) • Check for amperage in monitored conductor ($>0.5\text{ A}$) • Assure that sensor core mating surfaces are clean and that the core clamp is completely closed • Verify that the setpoint is not above operating amps by turning the setpoint screw counter-clockwise (up to 20 turns) until the contacts close (Status Closed LED turns on). Resume calibration from the beginning.
Setpoint screw has no stops	The 20 turn setpoint screw has a slip clutch to prevent damage at either end. To re-start the calibration process, turn the screw 20 full turns counter-clockwise. Resume calibration from the beginning.
Both LEDs are lit	The screw has been turned too far clockwise. Turn the screw 20 full turns counter-clockwise and resume calibration from the beginning.

PRODUCT INFORMATION

Ordering Code	Model Number	Description
324-0103-000	H608-S6	I-Sw,SP,50A,Out1A@30VAC/DC,NO